

ITEM	PART NUMBER	DESCRIPTION	QTY.
-	19900-00	CLAMP, AIR CLEANER	X
1	19900-00-01	CLAMP	1
2	19900-00-02	BRACKET	1
3	19900-00-03	CLAMP LINER	1

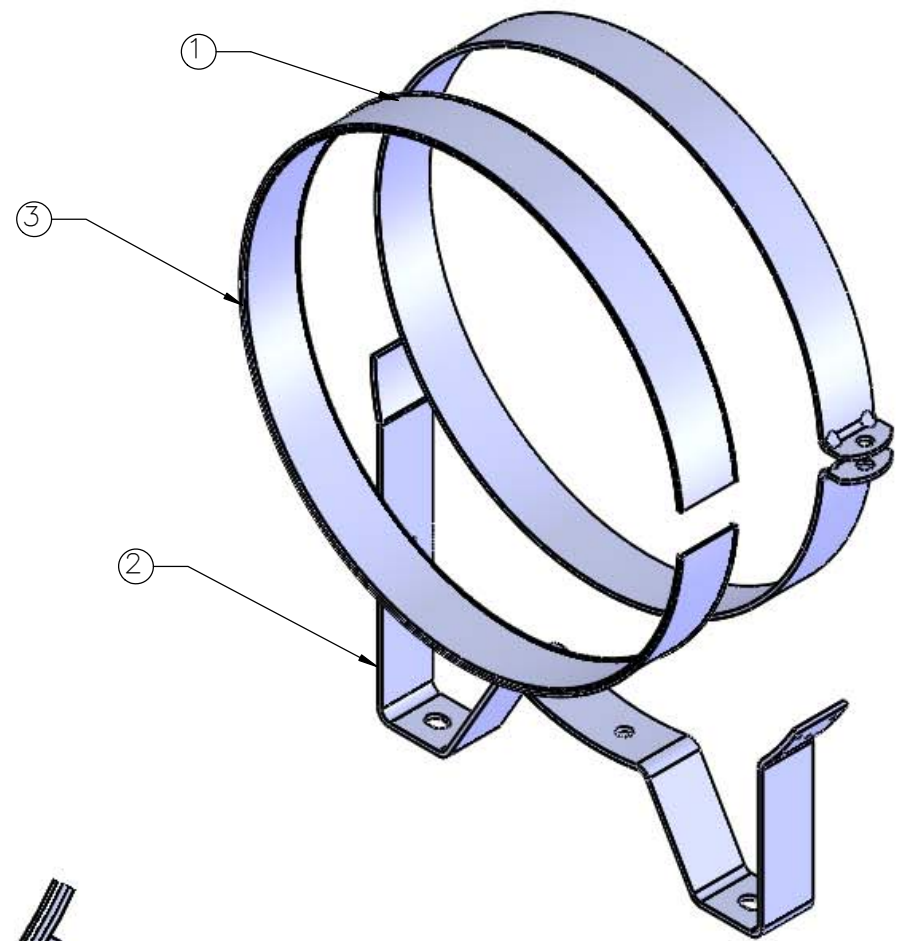
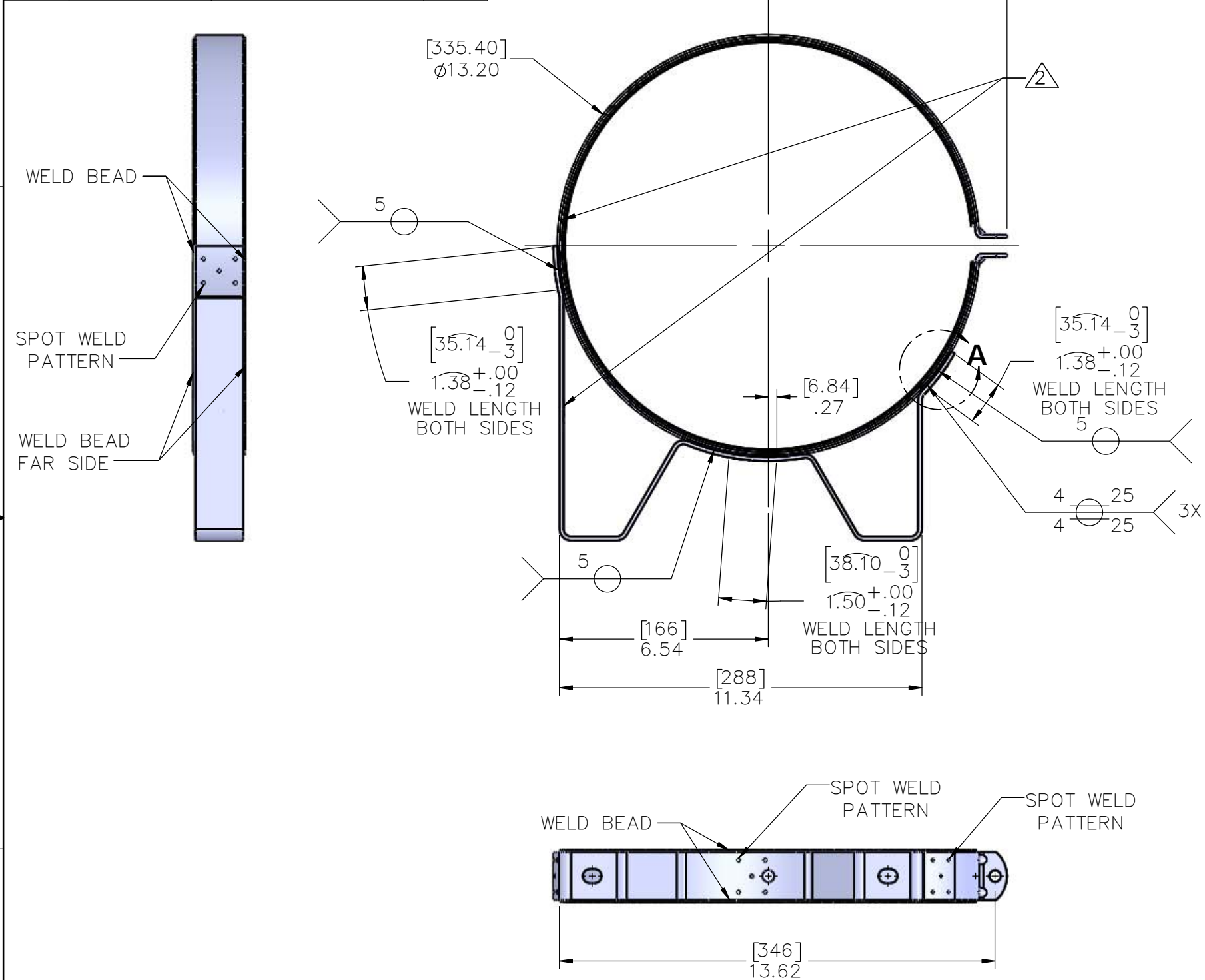

DETAIL A
SCALE 1 : 2

NOTES:

- ① ANNEAL AFTER WELDING @ 1090°C(1994°F) FOR 20 MINS.
- ② FINISH: POLISH TO A #8 FINISH AFTER WELDING.
- ③ INNER SURFACES DO NOT NEED TO BE POLISHED
- ④ CONTROL PRINT: P642120 REV 0.

REMOVE ALL BURRS & SHARP EDGES. ALL DIMENSIONS ARE IN INCHES UNLESS OTHERWISE NOTED.
TOLERANCES (EXCEPT AS NOTED)
TWO PLACE DECIMALS ±.01
THREE PLACE DECIMALS ±.005
FRACTIONS ±.015
SURFACE ROUGHNESS 63√ ±5°
ANGLES

DRWN	TJM	DATE
CK'D	BDS	08/18
APVD	BDS	08/18



B	ECN 20422; SEE ECN SH FOR CHANGES	TJM	VC	02/21
A	ECN 20271; SEE ECN SHEET FOR CHANGES	TJM	BDS	08/18
LTR	REVISION	BY	APVD	DATE
TITLE CLAMP, AIR CLEANER				
SCALE: 1:4	UNS NO. ~	MATL: ~	CAGE NO. 1RRL5	SIZE B
~	FINISH: SEE NOTE 1	~	ID CODE ~	DWG NO. 19900-00
				REV B