

ITEM	PART NUMBER	DESCRIPTION	QTY.
-	19900-01	CLAMP, AIR CLEANER	X
1	19900-01-01	CLAMP	1
2	19900-01-02	BRACKET	1
3	19900-01-03	CLAMP LINER	1

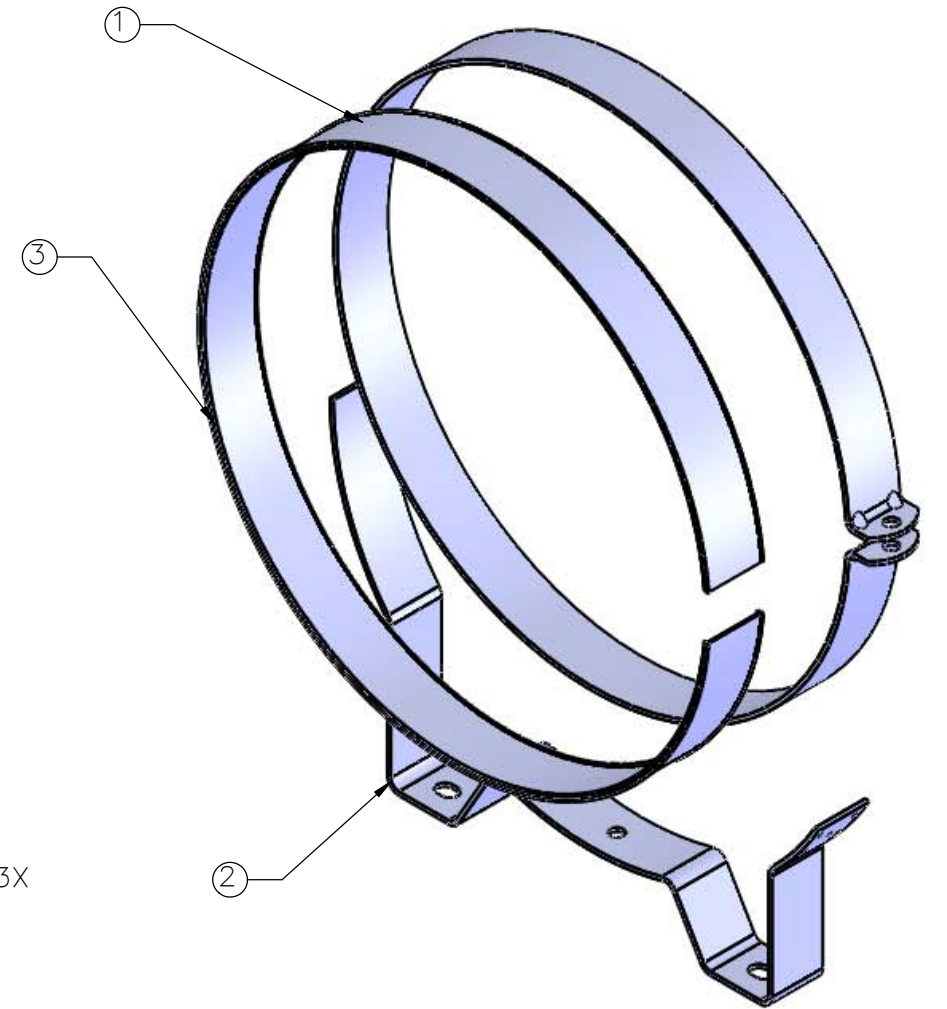
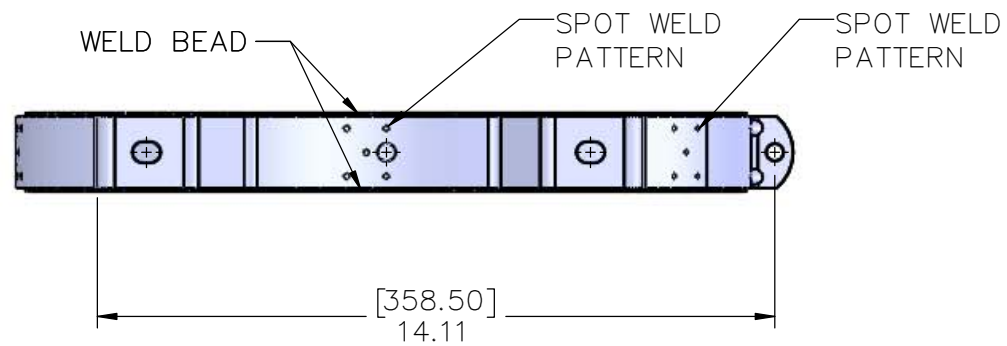
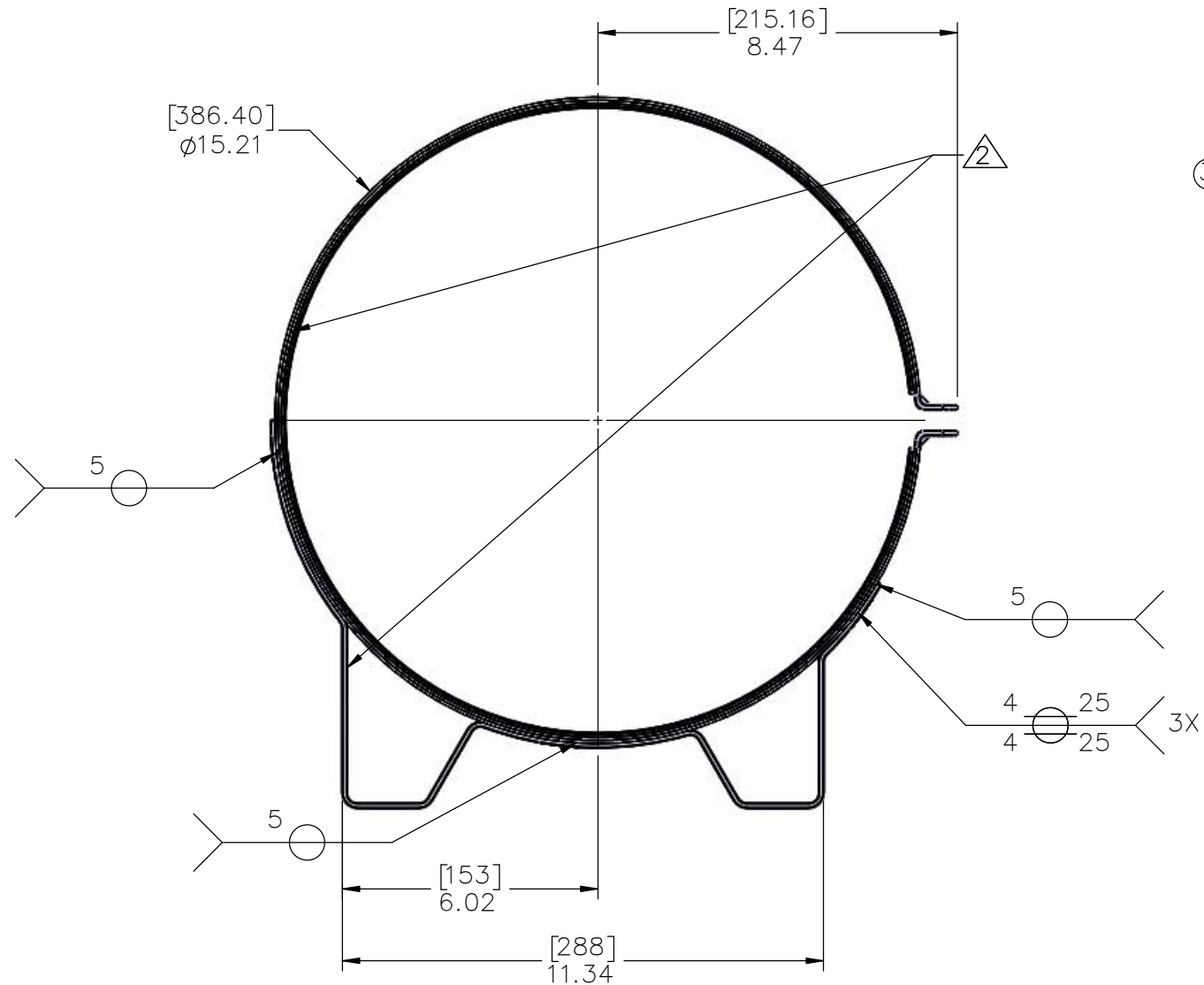
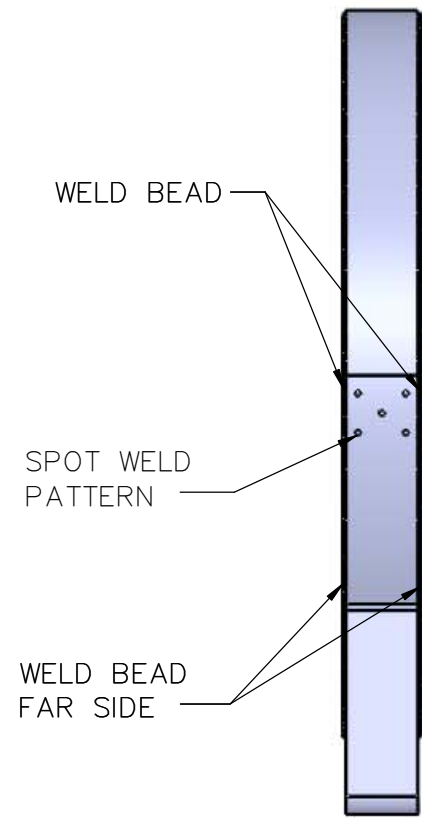

NOTES:

- ① ANNEAL AFTER WELDING @ 1090°C(1994°F) FOR 20 MINS.
- ② FINISH: POLISH TO A #7 FINISH.
- ② INNER SURFACES DO NOT NEED TO BE POLISHED
- ③ CONTROL PRINT: P642121 REV 0.

REMOVE ALL BURRS & SHARP EDGES. ALL DIMENSIONS ARE IN INCHES UNLESS OTHERWISE NOTED.

TOLERANCES (EXCEPT AS NOTED)

TWO PLACE DECIMALS ±.01
 THREE PLACE DECIMALS ±.005
 FRACTIONS ±.015

SURFACE ROUGHNESS 63
 ANGLES ±5°

DRWN	TJM	DATE
CK'D	BDS	08/18
APVD	BDS	08/18



SCALE: 1:4

UNS NO. ~
 ~

MATL: ~
 FINISH: ~

B	ECN 20422; SEE ECN SH FOR CHANGES	TJM	VC	02/21
A	ECN 20271; SEE ECN SHEET FOR CHANGES	TJM	BDS	08/18
LTR	REVISION	BY	APVD	DATE
TITLE CLAMP, AIR CLEANER				
CAGE NO.	SIZE	ID CODE	DWG NO.	REV
1RRL5	B	~	19900-01	B